



# International Journal of Multidisciplinary Research in Science, Engineering and Technology

*(A Monthly, Peer Reviewed, Refereed, Scholarly Indexed, Open Access Journal)*



**Impact Factor: 8.206**

**Volume 9, Issue 3, March 2026**



## International Journal of Multidisciplinary Research in Science, Engineering and Technology (IJMRSET)

(A Monthly, Peer Reviewed, Refereed, Scholarly Indexed, Open Access Journal)

# Automatic Plant Watering System with using Soil Moisture Sensor

Dudhbhate Komal Kisan<sup>1</sup>, Jagtap Nikita Ramdas<sup>1</sup>, Devkate Bhakti Ashok<sup>1</sup>, Ghate Pranvi Ranvir<sup>1</sup>,  
Ms.More Gayatri Eknath<sup>1</sup>, Prof.A.B.Manidarkar<sup>2</sup>

Diploma Student, Dept. of Electronic and Telecommunication Engg., Government Polytechnic, Osmanabad, India<sup>1</sup>

Guide, Dept. of Electronic and Telecommunication Engg., Government Polytechnic, Osmanabad, India<sup>2</sup>

**ABSTRACT:** This project is undertaken considering that India is an agriculture-oriented country where the rapid depletion of water resources poses a serious challenge. Therefore, there is a need for a smart and efficient irrigation system to ensure optimal water utilization. In this project, soil moisture sensors are used to detect the water content in the soil and automatically supply water to the areas that require irrigation. The system is based on the PIC16F877A microcontroller, which controls the entire irrigation process. Sensors are installed in different sections of the field, and they remain inactive as long as sufficient moisture is present. When the soil becomes dry, the sensors detect the low moisture level and send a signal to the microcontroller. The microcontroller then activates the water supply to the specific area until the required moisture level is restored, after which the system stops watering automatically. In situations where multiple areas simultaneously require water, the microcontroller prioritizes the first received signal and irrigates the fields accordingly. The system is programmed to continuously monitor soil conditions and provide water only when necessary, ensuring efficient water usage. This type of automated irrigation system is suitable for both small gardens and large agricultural fields. Typically, plants require watering at regular intervals, such as in the morning and evening. The microcontroller can be programmed to maintain such schedules while also responding dynamically to real-time soil conditions. Many people enjoy maintaining plants, but due to busy schedules or extended periods away from home, it becomes difficult to care for them properly. This project addresses that issue by providing an automated solution that assists users in maintaining healthy plants without constant manual intervention. The system is designed to be user-friendly, reliable, and beneficial for both agricultural and domestic applications.

**KEYWORDS:** Automatic Irrigation, Soil Moisture Sensor, Arduino UNO, Smart Agriculture, Water Management

## I. INTRODUCTION

Agriculture plays a vital role in the economy, especially in countries like India. One of the major challenges faced by farmers is efficient irrigation due to unpredictable rainfall and limited water resources. Traditional irrigation methods require manual monitoring, which consumes time and labor.

An automatic plant watering system provides a smart solution by using sensors and microcontrollers to automate irrigation. This system ensures that plants receive water only when needed, preventing overwatering and underwatering.

In greenhouse environments, maintaining proper humidity is also essential. High humidity levels can lead to plant diseases, while low humidity can affect plant growth. Therefore, controlled irrigation is necessary for maintaining optimal conditions.

## II. LITERATURE REVIEW

Various irrigation systems have been developed using embedded systems and IoT technologies. These systems focus on:

- Monitoring soil moisture
- Automating irrigation processes
- Reducing water wastage



## International Journal of Multidisciplinary Research in Science, Engineering and Technology (IJMRSET)

(A Monthly, Peer Reviewed, Refereed, Scholarly Indexed, Open Access Journal)

However, many existing systems are expensive or complex. This project provides a cost-effective and simple solution using readily available components.

### III. METHODOLOGY

The system operates based on sensor input and automated control.

#### 3.1 Working Principle

1. The soil moisture sensor continuously monitors the water content in the soil by detecting changes in its electrical properties and generates an analog or digital signal based on the moisture level.
2. This signal is transmitted to the Arduino microcontroller, which acts as the central processing unit and reads the sensor data for further analysis.
3. The Arduino compares the received moisture value with a predefined threshold level stored in the program to determine whether the soil is dry or adequately moist.
4. If the moisture level is below the threshold, the Arduino sends a control signal to the relay module, which acts as a switch to activate the water pump and supply water to the plants.
5. As the soil absorbs water and reaches the desired moisture level, the Arduino deactivates the relay, turning off the pump and ensuring efficient water usage without manual intervention.

#### 3.2 System Design

The system includes:

- Sensing unit (soil moisture sensor)
- Control unit (Arduino UNO)
- Actuation unit (relay + water pump)

### IV. HARDWARE COMPONENTS

#### 4.1 Arduino UNO

The Arduino UNO is the main controller based on ATmega328P microcontroller.

##### Features:

- 14 digital pins
- 6 analog inputs
- 16 MHz clock
- USB interface

#### 4.2 Soil Moisture Sensor

The soil moisture sensor measures the water content of soil.

##### Pin Configuration:

- VCC – Power supply
- GND – Ground
- A0 – Analog output
- D0 – Digital output

##### Working:

It works on the principle of capacitance and detects soil moisture based on dielectric permittivity.

#### 4.3 Relay Module

A relay acts as a switch to control the water pump.

##### Function:

- Turns pump ON/OFF based on Arduino signal
- Provides electrical isolation

#### 4.4 Li-ion Battery

Provides power supply to the system.

##### Advantages:

- Rechargeable



## International Journal of Multidisciplinary Research in Science, Engineering and Technology (IJMRSET)

(A Monthly, Peer Reviewed, Refereed, Scholarly Indexed, Open Access Journal)

- High efficiency
- Lightweight

### 4.5 Water Pump

Used to supply water to plants automatically.

## V. CIRCUIT DIAGRAM

The system consists of:

- Soil moisture sensor connected to analog pin (A0)
- Relay module connected to digital pin
- Water pump connected through relay
- Power supply connected to Arduino

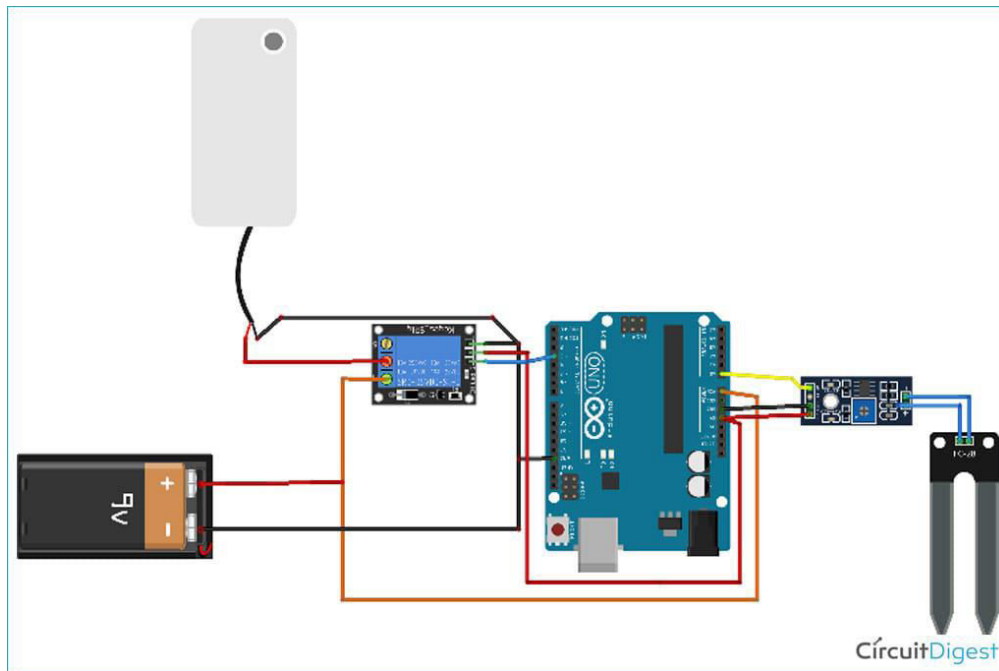

Figure 1: Circuit diagram of Automatic Plant Watering System

Arduino acts as the central controller and processes all inputs and outputs.

## VI. SOFTWARE IMPLEMENTATION

### 6.1 Development Tool

- Arduino IDE

### 6.2 Algorithm

1. Initialize system
2. Read moisture value
3. Compare with threshold
4. If dry → ON pump
5. If wet → OFF pump
6. Repeat continuously



## International Journal of Multidisciplinary Research in Science, Engineering and Technology (IJMRSET)

(A Monthly, Peer Reviewed, Refereed, Scholarly Indexed, Open Access Journal)

### VII. WORKING

When the system is powered:

- The soil moisture sensor continuously monitors soil condition
- If soil is dry, Arduino activates the relay
- The relay switches ON the water pump
- Water is supplied until the desired moisture level is reached
- Once sufficient moisture is detected, the pump is turned OFF

This ensures efficient water usage and healthy plant growth.

### VIII. RESULTS AND TESTING

The system was tested under different soil conditions:

- Accurate moisture detection
- Automatic pump operation
- Reliable performance

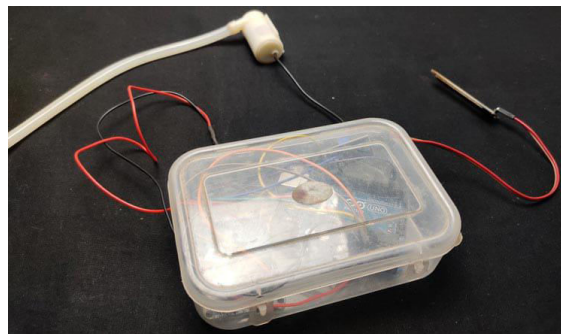

Figure 2: Arduino based Automatic Irrigation System

The system successfully reduced water wastage and ensured proper irrigation.

#### Advantages

- Reduces manual labor
- Saves water
- Provides timely irrigation
- Cost-effective
- Easy to use



## International Journal of Multidisciplinary Research in Science, Engineering and Technology (IJMRSET)

(A Monthly, Peer Reviewed, Refereed, Scholarly Indexed, Open Access Journal)

### Disadvantages

- Initial setup cost
- Requires maintenance
- Sensor accuracy depends on soil type

### Applications

- Home gardening
- Agriculture fields
- Greenhouses
- Landscaping

### Future Enhancements

- IoT-based remote monitoring
- Mobile app control
- Weather-based irrigation system
- Solar-powered system

## IX. CONCLUSION

The automatic plant watering system provides an efficient and reliable solution for modern irrigation management by utilizing sensors to continuously monitor soil moisture levels and automatically supplying water when required. This eliminates the need for constant human intervention and ensures that plants receive the appropriate amount of water at the right time. By preventing both overwatering and underwatering, the system helps conserve water and reduces wastage significantly. It also saves time and labor, making it especially useful for farmers and individuals with busy schedules. Additionally, consistent and controlled watering improves plant health, growth, and productivity. The system is suitable for a wide range of applications, including home gardens, greenhouses, and agricultural fields, and serves as an effective step toward smart agriculture and sustainable resource management.

## REFERENCES

1. Arduino Official Website, "Arduino UNO Documentation and Resources," Available at: <https://www.arduino.cc>
2. Wikipedia, "Soil Moisture Sensor," Available at: [https://en.wikipedia.org/wiki/Soil\\_moisture\\_sensor](https://en.wikipedia.org/wiki/Soil_moisture_sensor)
3. ResearchGate, "Automatic Irrigation System Using Soil Moisture Sensor," Available at: <https://www.researchgate.net>
4. Microchip Technology Inc., "PIC16F877A Microcontroller Datasheet," Available at: <https://www.microchip.com>
5. International Journal of Engineering Research & Technology (IJERT), "Smart Irrigation System Using Arduino," Available at: <https://www.ijert.org>



INTERNATIONAL  
STANDARD  
SERIAL  
NUMBER  
INDIA



# INTERNATIONAL JOURNAL OF MULTIDISCIPLINARY RESEARCH IN SCIENCE, ENGINEERING AND TECHNOLOGY

| Mobile No: +91-6381907438 | Whatsapp: +91-6381907438 | [ijmrset@gmail.com](mailto:ijmrset@gmail.com) |

[www.ijmrset.com](http://www.ijmrset.com)